



National Institute of Standards and Technology
U.S. Department of Commerce

NBSR DEUTERIUM COLD SOURCE: COMPRESSOR MOTOR STARTUP

Center for Neutron Research, National Institute of Standards and
Technology, 100 Bureau Dr.,
20899 Gaithersburg, MD, USA

Andrew W. Main

Disclaimer

Certain commercial equipment, instruments, or materials are identified in this presentation. Such identification is not intended to imply recommendation or endorsement by the National Institute of Standards and Technology, nor is it intended to imply that the materials or equipment identified are necessarily the best available for the purpose.

- The National Bureau of Standards Reactor (NBSR), located at the NIST Center for Neutron Research (NCNR) in Gaithersburg, MD, is currently in the process of replacing the existing cold neutron source with a new liquid deuterium cold neutron source.
- One of the first phases of this project included the installation of a new 7kW refrigerator system complete with two 100% redundant, 800 HP, 4160V Compressors.

Background

Electrical Distribution System

- The power supplied to these compressors starts at the substation's three 1500kVA, 13.8kV-480V step-down transformers which supply the substation's 480V switchgear.
- From the switchgear, 480V power is transmitted via five sets of three single conductor 500 kcmil cables to the compressor building 480V switchboard.
- From the switchboard, 480V power is transmitted via four sets of three single conductor 600 kcmil cables to a 750kVA, 480V-4160V step-up transformer.
- From the transformer, 4160V power is transmitted via #2 AWG cables to each compressor's soft starter.

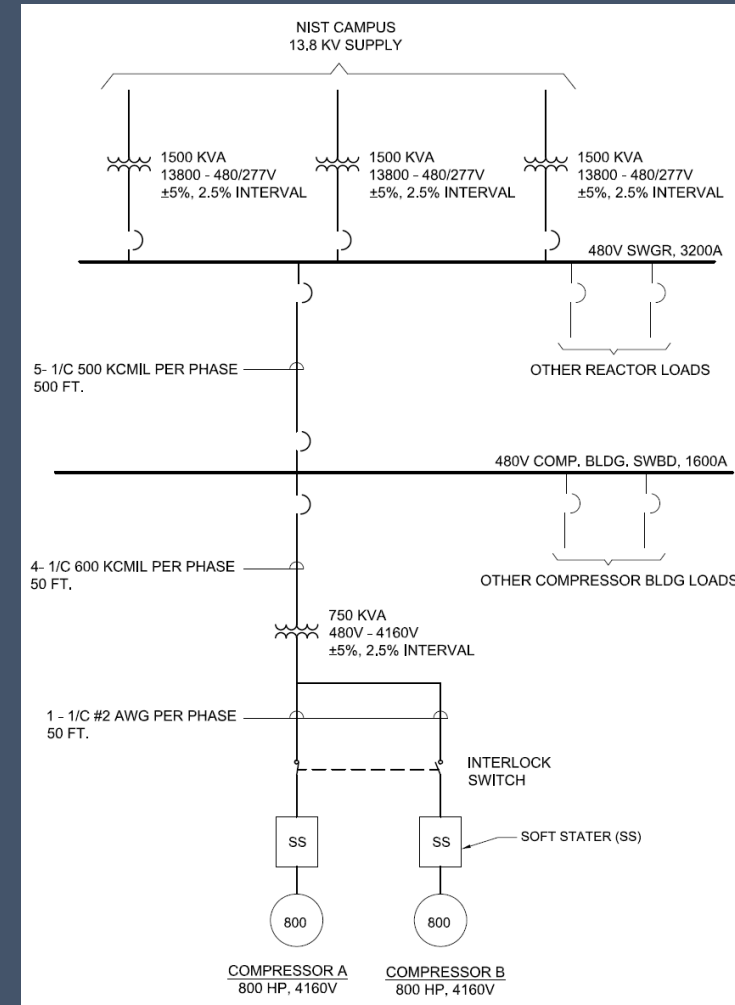

Background

Compressor Motor Electrical Characteristics:

• Rated Size:	800 HP
• Rated Voltage:	4160V
• Power Factor:	0.87
• Efficiency:	95.5%
• Full Load Current (FLC):	99.7A *
• Across the line start-up current (550% of FLC):	~554A **
• Demand Load	~ 80%

* The current seen on the 480V distribution system during normal operation is 864A.

**The current seen on the 480V distribution system during an across the line start-up is ~4800A.

Background

Soft Starter

- Soft starters use phase angle firing control of Silicon Controlled Rectifiers (SCRs) to apply a reduced voltage to the motor, and then slowly and gently increases torque using voltage and current control until the motor accelerates to full speed. This starting method lowers the starting current of the motor and reduces stress on the electrical distribution system and the motor.

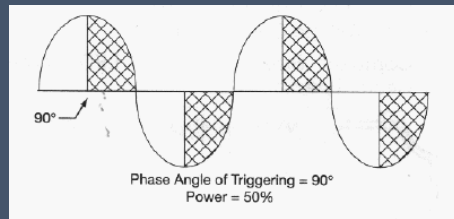

- For instances where the electrical distribution system is limited, the soft starter can be setup to gradually increase voltage and current until a maximum current limit set point is reached where it is held until the motor accelerates to full speed. The current limit setpoint is a multiple of the motor's full load current, and ranges between 200% and 500% with adjustment increments of 10%.



Background

Evolution of the Electrical Distribution System

- The 480V distribution system was designed and installed several years prior to the design of the new cold source refrigerator under the assumption the new system would be equipped with 480V compressors consistent with the existing cold source system.
- Actual design called for 4160V, 800HP compressors.
- Accommodations were made for the new compressors, thus, a 480V to 4160V Step-up transformer and soft starter were installed.
- Resulting in the unconventional and inefficient design.

Background

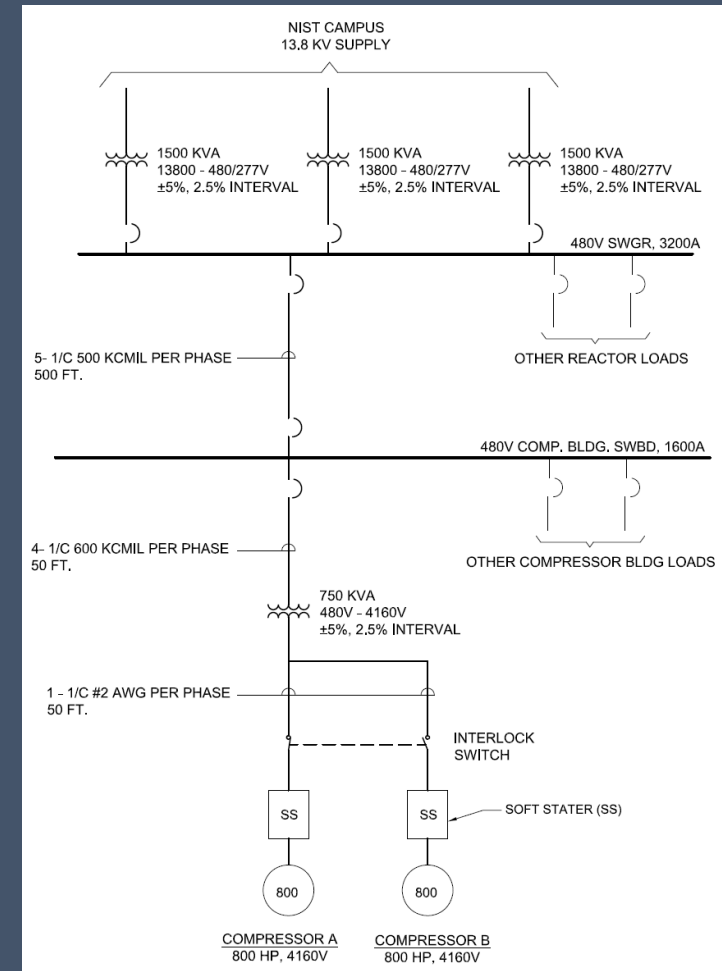

- Installation of the new refrigerator system was completed in early 2016
- The soft starter current limit settings for the initial startup attempts were as follows:

Parameter	Attempt A	Attempt B
Current Limit	350%	400%
Undervoltage Trip Setting	15% (Below Nominal)	20% (Below Nominal)
Undervoltage Trip Delay	2 seconds	4 seconds

- Both attempts failed due to an undervoltage condition seen at the soft starter. Unfortunately, metering of voltage and current was not performed.
- STAR Principle (Stop, Think, Act, Review)
- Testing was immediately put on hold until an assessment of the system was performed.

Issues

- Add an additional set of cables between the 480V SWGR and the 480V Compressor Building Switchboard.
 - Falls short of resolving voltage drop issue (reduces voltage drop by <1%)
- Install a new 4160V Power Distribution System dedicated to the Compressor Motors.
 - Extremely expensive
 - Major schedule impacts

Contractor Recommendations

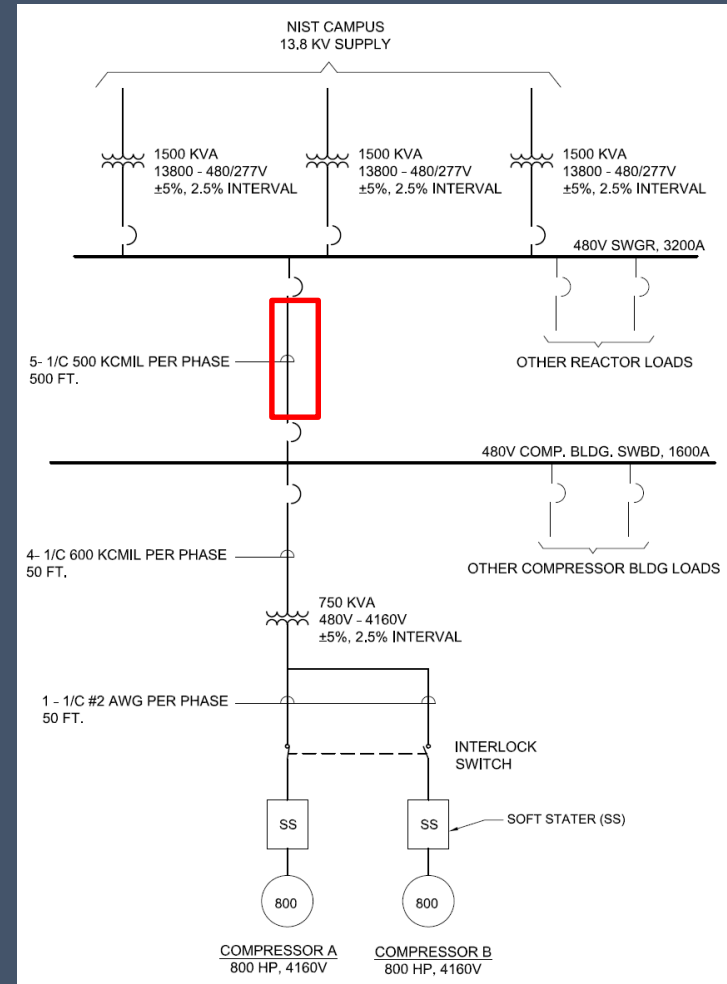

- An in-house analysis was performed to determine the effects on the electrical distribution system during normal compressor operation and during compressor motor startup.
 - The analysis was performed at the compressor motor's FLC value and at different starting current limit settings (250% to 400% of motors FLC).
- The analysis determined the distribution system was sufficiently sized for normal operation of the compressor motors.
- Although the analysis used a few conservative assumptions it highlighted specific areas of the distribution system where significant voltage drops would be seen during motor startup:
 - 1500 kVA, 13.2kV-480V step-down SWGR transformers (2.5% to 4%)
 - Feeder Cable between the 480V SWGR and the 480V Compressor Building Switchboard (4% to 6.5%)
 - 750KVA Compressor Motor step-up transformer (15% to 24%)

% of FLC	VD @ 480V SWGR	VD @ 480V COMP. BLDG. SWBD	VD @ 4160V Soft Starter
100	1.00%	2.68%	6.40%
250	2.46%	6.65%	21.97%
300	2.95%	7.98%	26.36%
350	3.44%	9.31%	30.75%
400	3.93%	10.64%	35.15%

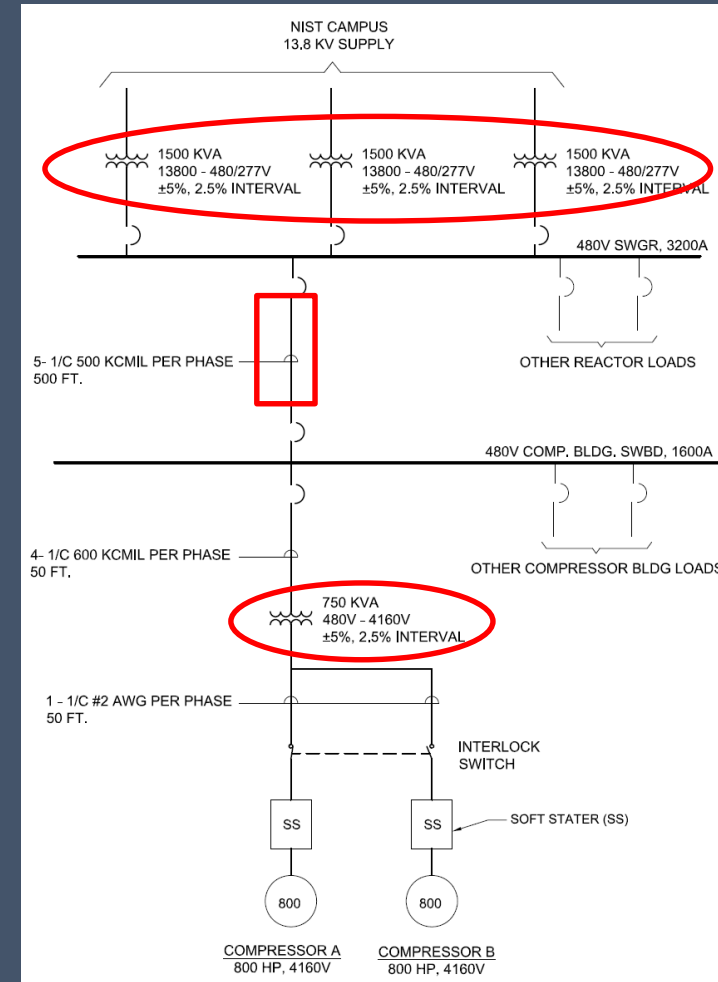

Electrical Analysis

Options Considered:

- Increase cable sizes/quantities
 - (6) 500 kcmil cables per phase (reduces voltage drop by <math><1.0\%</math>)
 - (6) 600 kcmil cables per phase (reduces voltage drop by <math><1.3\%</math>)
 - (6) 750 kcmil cables per phase (reduces voltage drop by <math><1.7\%</math>)
- Increase Transformer Tap Settings (i.e., boosting secondary voltage)
- Increase the size of the Compressor Motor Transformer
- Adjust Soft Starter Settings
 - Lower the soft starter undervoltage setting and increase delay setting
 - Lower motor startup current limit setting

Electrical Analysis

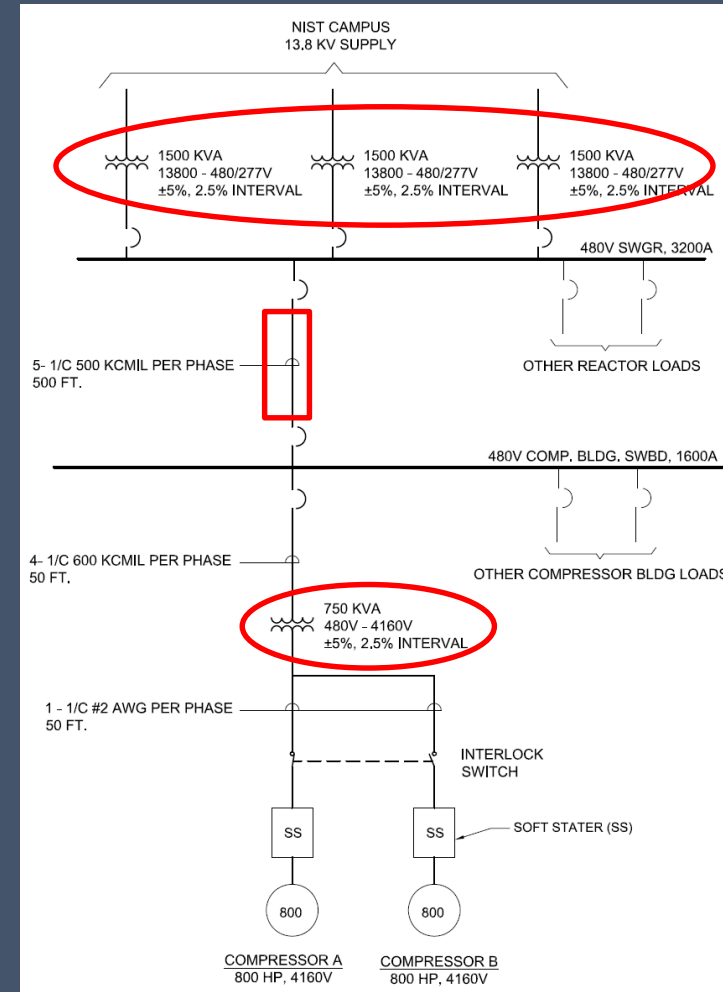

Motor Start-up Plan

- Attempt to start the compressor motor in the softest configuration possible by:
 - Lowering the soft starter undervoltage setting to 25% below nominal with a delay of 3 seconds.
 - Lowering the motor startup current limit of the soft starter to 300% (i.e., limiting voltage drop during startup, but it also lowers the available starting torque)
 - Limiting the load on the compressor (i.e., limiting starting torque)
- Once the motor successfully started, additional startup attempts would be performed at different current limit setpoints (i.e., 250% and 350%) to determine the range of settings that would ensure a successful start.

Startup tests

Motor Start-up Plan

- Voltage monitored at the following locations:
 - 480V switchgear
 - Compressor building 480V switchgear
 - Soft starter
- 480V SWGR voltage typically 3% higher than nominal.

Startup tests

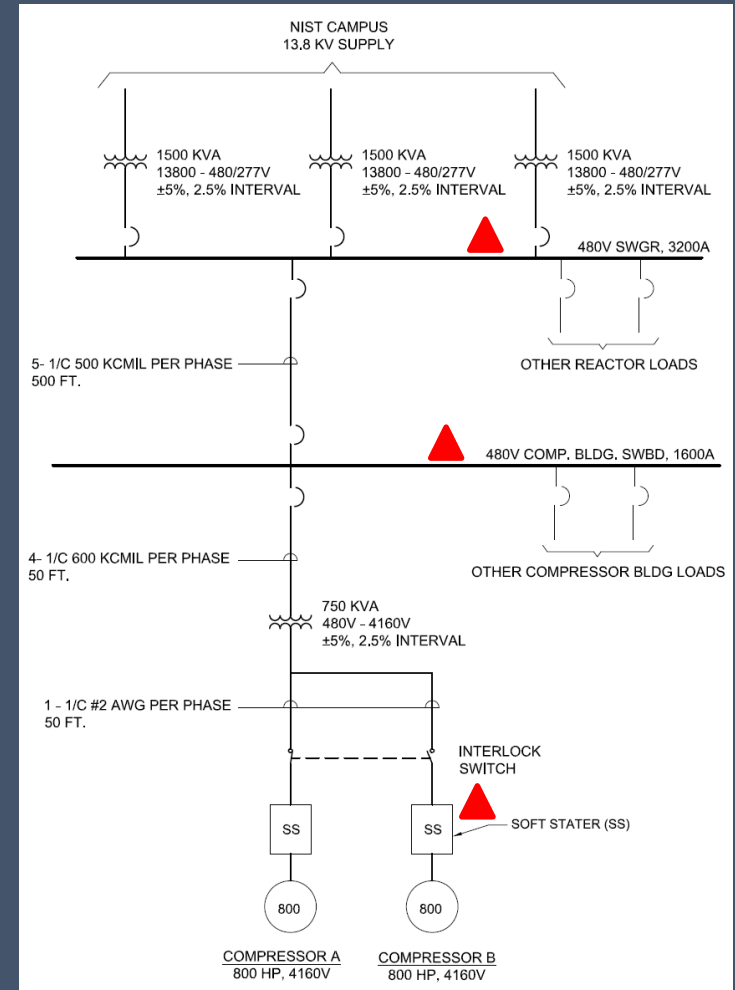

Location	Test #1 (300%)
480V SWGR Initial Voltage	497.8
480V SWGR Initial Voltage (% from Nominal)	103.71%
480V SWGR Startup Voltage	479.1
480V SWGR Startup Voltage % VD (total)	3.76%
480V SWGR Startup Voltage % VD (from Nominal)	0.19%
CP Bldg 480V SWBD Initial Voltage	494.4
CP Bldg 480V SWBD Initial Voltage (% from Nominal)	103.00%
CP Bldg 480V SWBD Startup Voltage	456.8
CP Bldg 480V SWBD Startup Voltage % VD (total)	7.61%
CP Bldg 480V SWBD Startup Voltage % VD (from Nominal)	4.83%
4160V Soft Starter Initial Voltage	4346
4160V Soft Starter Initial Voltage (%from Nom)	104.47%
4160V Soft Starter Startup Voltage	3389
4160V Soft Starter Startup Voltage % VD (total)	22.02%
4160V Soft Starter Startup Voltage % VD (from Nom)	18.53%
Startup Time (secs)	10.52

- Compressor motor startup attempt was successful.

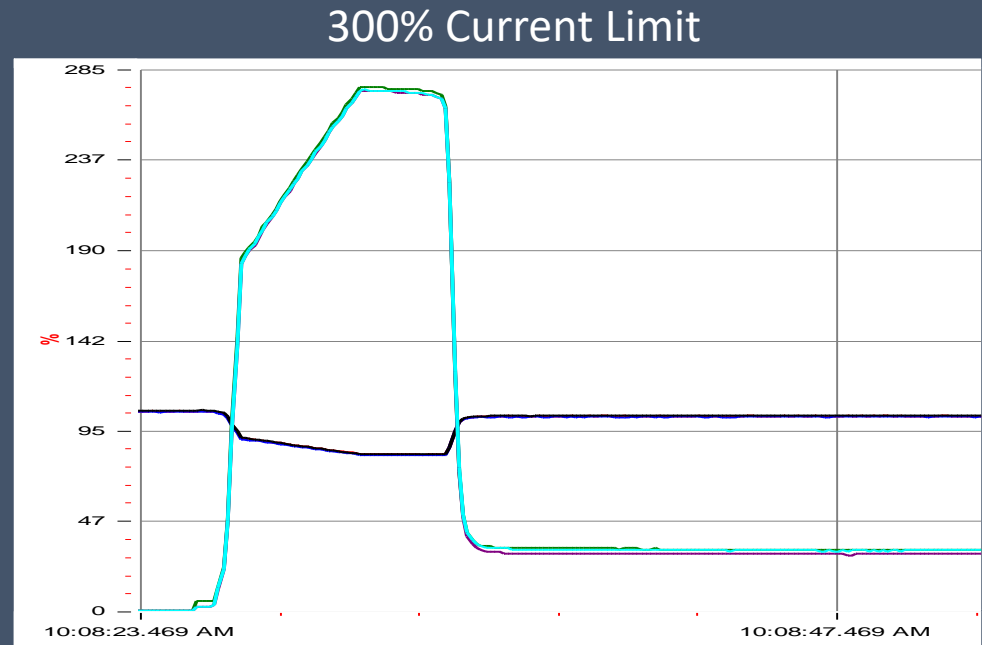

Voltage & Current at Soft Starter

Startup tests

Location	Test #2 (250%)
480V SWGR Initial Voltage	494.4
480V SWGR Initial Voltage (% from Nominal)	103.00%
480V SWGR Startup Voltage	480
480V SWGR Startup Voltage % VD (total)	2.91%
480V SWGR Startup Voltage % VD (from Nominal)	0.00%
CP Bldg 480V SWBD Initial Voltage	492.4
CP Bldg 480V SWBD Initial Voltage (% from Nominal)	102.58%
CP Bldg 480V SWBD Startup Voltage	460.3
CP Bldg 480V SWBD Startup Voltage % VD (total)	6.52%
CP Bldg 480V SWBD Startup Voltage % VD (from Nominal)	4.10%
4160V Soft Starter Initial Voltage	4329
4160V Soft Starter Initial Voltage (%from Nom)	104.06%
4160V Soft Starter Startup Voltage	3556
4160V Soft Starter Startup Voltage % VD (total)	17.86%
4160V Soft Starter Startup Voltage % VD (from Nom)	14.52%
Startup Time (secs)	---

- Compressor motor failed to reach speed, thus, startup attempt was aborted.

Startup tests

250% Current Limit

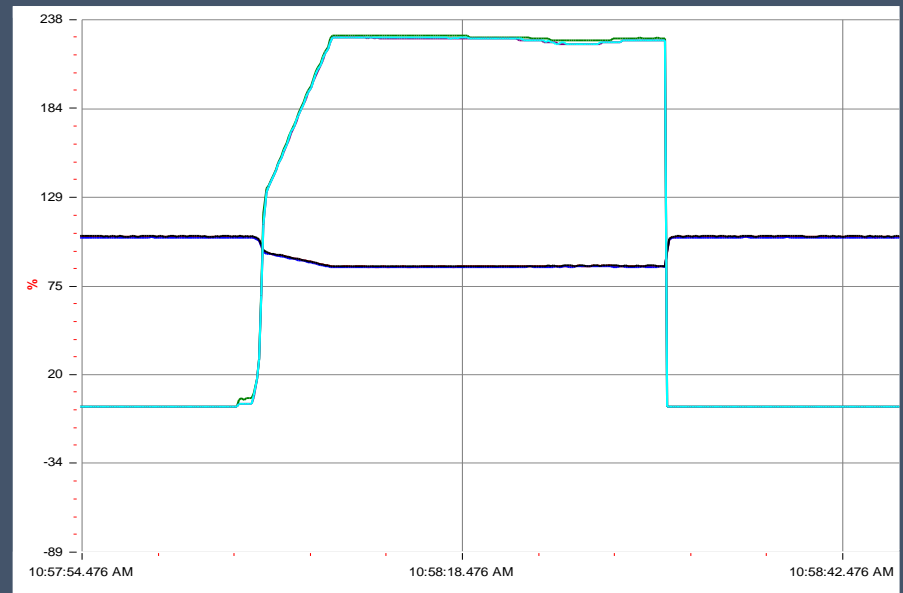

Voltage & Current at Soft Starter

Location	Test #3 (350%)
480V SWGR Initial Voltage	493.5
480V SWGR Initial Voltage (% from Nominal)	102.81%
480V SWGR Startup Voltage	472.8
480V SWGR Startup Voltage % VD (total)	4.19%
480V SWGR Startup Voltage % VD (from Nominal)	1.50%
CP Bldg 480V SWBD Initial Voltage	490.5
CP Bldg 480V SWBD Initial Voltage (% from Nominal)	102.19%
CP Bldg 480V SWBD Startup Voltage	446.7
CP Bldg 480V SWBD Startup Voltage % VD (total)	8.93%
CP Bldg 480V SWBD Startup Voltage % VD (from Nominal)	6.94%
4160V Soft Starter Initial Voltage	4316
4160V Soft Starter Initial Voltage (%from Nom)	103.75%
4160V Soft Starter Startup Voltage	3170
4160V Soft Starter Startup Voltage % VD (total)	26.55%
4160V Soft Starter Startup Voltage % VD (from Nom)	23.80%
Startup Time (secs)	7.41

- Compressor motor startup attempt was successful.

350% Current Limit

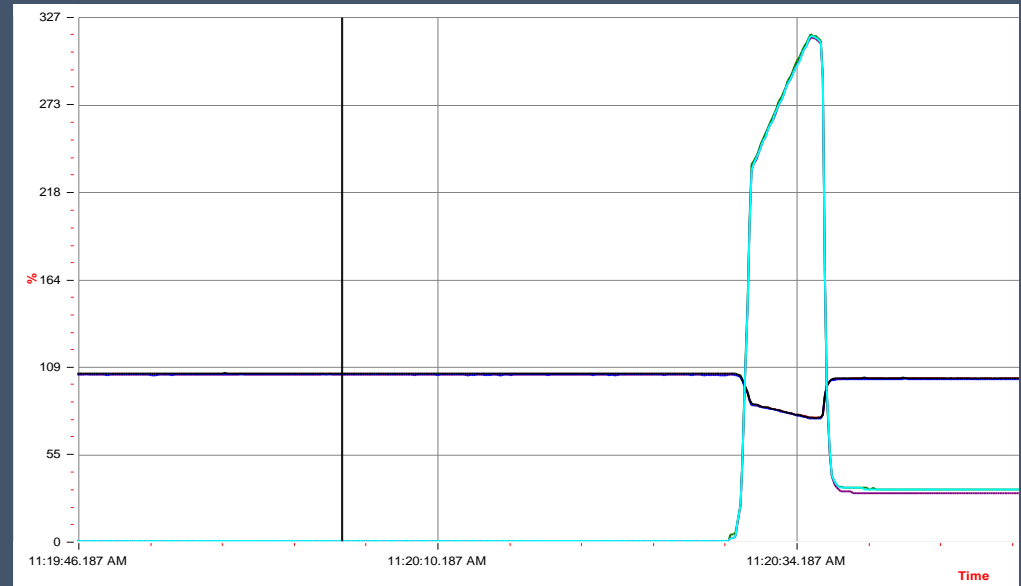

Voltage & Current at Soft Starter

Startup tests

Summarized Results

It was concluded that the following soft starter settings will allow for a successful compressor motor startup:

- Current Limit Setting: 300% - 350%
- Undervoltage Setting: 25%
- Undervoltage Delay: 3 seconds

Additional modifications may be implemented in the future to enhance the compressor's distribution system (i.e., increase cable sizes, increase transformer size or tap setting, additional adjustments to soft starter).

Location	Test #1 (300%)	Test #2 (250%)	Test #3 (350%)
480V SWGR Initial Voltage	497.8	494.4	493.5
480V SWGR Initial Voltage (% from Nominal)	103.71%	103.00%	102.81%
480V SWGR Startup Voltage	479.1	480	472.8
480V SWGR Startup Voltage % VD (total)	3.76%	2.91%	4.19%
480V SWGR Startup Voltage % VD (from Nominal)	0.19%	0.00%	1.50%
CP Bldg 480V SWBD Initial Voltage	494.4	492.4	490.5
CP Bldg 480V SWBD Initial Voltage (% from Nominal)	103.00%	102.58%	102.19%
CP Bldg 480V SWBD Startup Voltage	456.8	460.3	446.7
CP Bldg 480V SWBD Startup Voltage % VD (total)	7.61%	6.52%	8.93%
CP Bldg 480V SWBD Startup Voltage % VD (from Nominal)	4.83%	4.10%	6.94%
4160V Soft Starter Initial Voltage	4346	4329	4316
4160V Soft Starter Initial Voltage (%from Nom)	104.47%	104.06%	103.75%
4160V Soft Starter Startup Voltage	3389	3556	3170
4160V Soft Starter Startup Voltage % VD (total)	22.02%	17.86%	26.55%
4160V Soft Starter Startup Voltage % VD (from Nom)	18.53%	14.52%	23.80%
Startup Time (secs)	10.52	---	7.41

Startup tests

- Successful startup of the compressors has allowed the project to move forward without any additional delays. The compressors will be placed in service this fall.
- Lesson's Learned:
 - Be aware of the effects of design evolution
 - Verify contractor's recommendations will solve the problem
 - Ensure qualified individuals review design submittals

Conclusion

Thank You!