

I GORR Conference 2010

Knoxville – USA

19-24 September 2010

**Implementation of Molybdenum Production
in Polish Research Reactor MARIA**

Andrzej Gołąb

Institute of Atomic Energy POLATOM

05-400 OTWOCK, POLAND

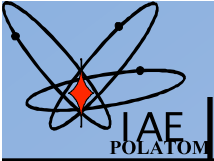

Scope

1. Introduction
2. Short presentation of High Flux Reactor MARIA
3. Uranium plates irradiation for molybdenum production in MARIA reactor
4. Transport of irradiated plates to the hot cell
5. Loading of irradiated plates into Marianne container
6. Conclusion

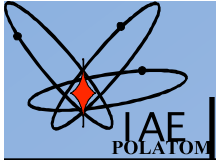

1. Introduction

Research reactor MARIA is a multipurpose high flux reactor of 30 MW nominal thermal power, operated from 1974. The large upgrading of reactor was performed in the years 1985-1992. Reactor utilization is radioisotopes production, horizontal beam tubes are utilized for neutron physics, and training. In 2009 the implementation of new medical application of the reactor for molybdenum production was developed and at the beginning of this year the commercial irradiation was started.

In the paper the technological process of highly enriched uranium plates irradiations is presented as well as adaptation of reactor infrastructure for irradiated plates expedition.

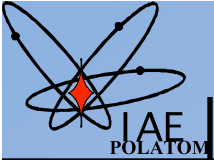

2. Short presentation of High Flux Research Reactor MARIA

- Designed and constructed by Polish industry
- First criticality was reached in December 1974
- 1985 ÷ 1991 – modernization period:
 - removal of graphite blocks from the proximity of fuel channels
 - upgrading of heat exchangers
 - upgrading of ventilation system
 - replacement of closing valves in primary cooling system (the old valves didn't meet the safety principles)
 - upgrading of protection system
- Put again into operation in 1992

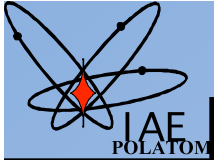

General characteristics of MARIA reactor

Nominal power	30MW
Maximum thermal neutron flux: in fuel in beryllium	2.5 · 10 ¹⁸ n / m ² s 4.0 · 10 ¹⁸ n / m ² s
Moderator	water and beryllium
Reflector	graphite (blocks in Al cans) and water
Fuel element: material enrichment shape overall dimensions	U-Al alloy clad in Al. 36% U-235 Six concentric tubes 100 cm high
Primary fuel cooling system: type of fuel channel pressure range temperature, core inlet (outlet), water flow rate: per channel total	Field tube 0.8 ÷ 1.8 Mpa 50 (100) °C 25 m ³ / h 550 ÷ 650 m ³ / h
Primary pool cooling system: pressure temperature: at core matrix inlet at core matrix outlet Water flow rate	Atmospheric 40 °C 50 °C 1400 m ³ / h

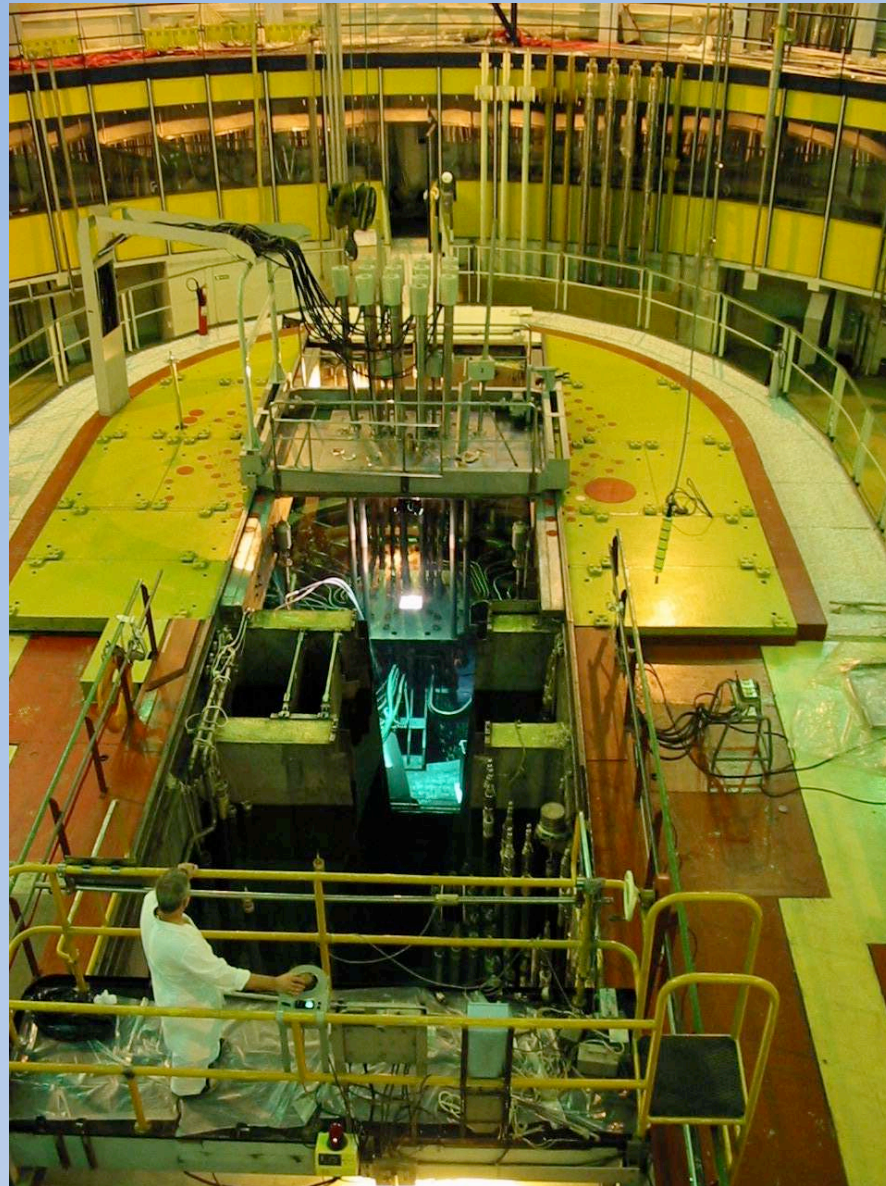

Fig.1. View on the reactor pools

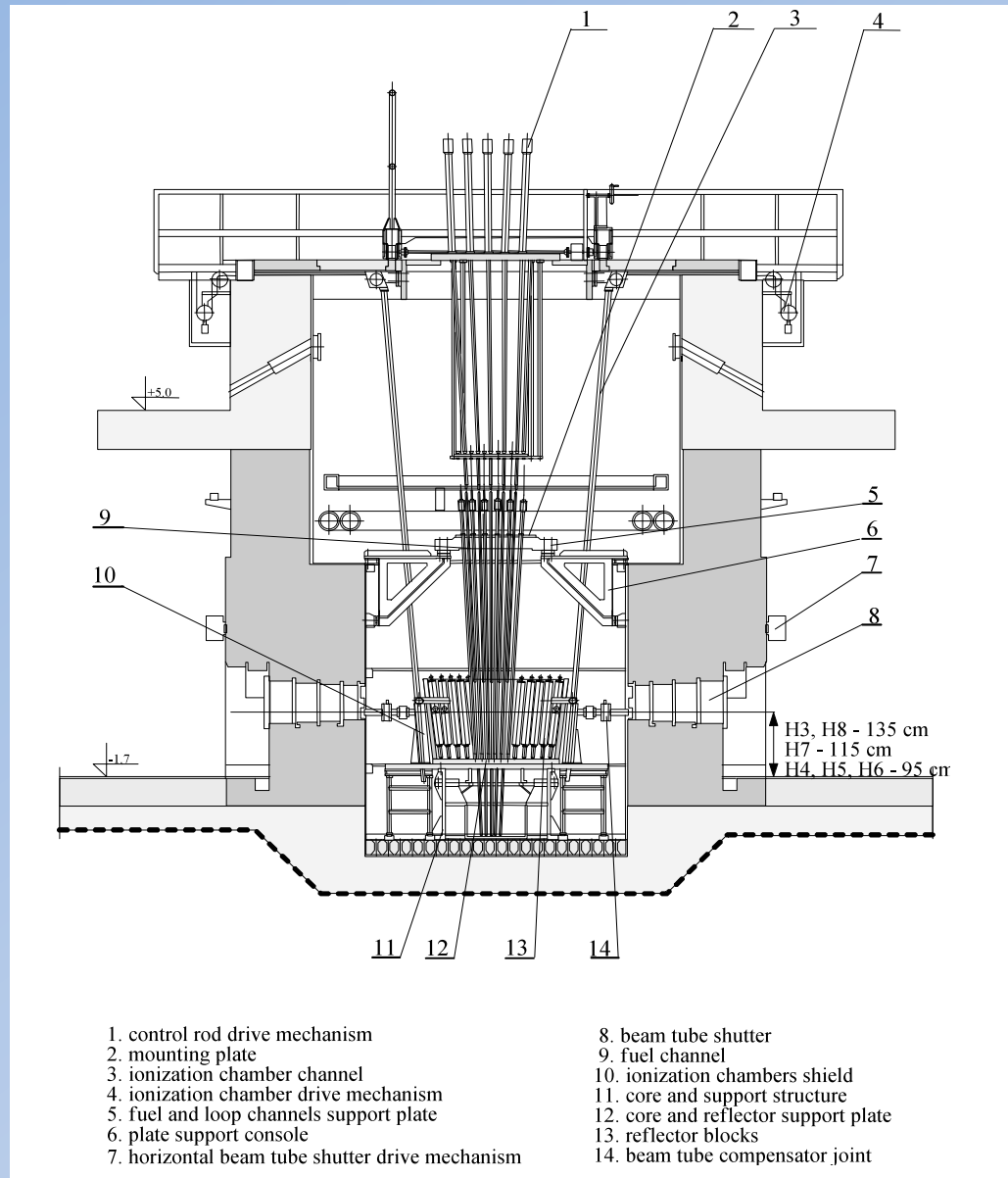

Fig.2. Vertical cross-section of the reactor pool

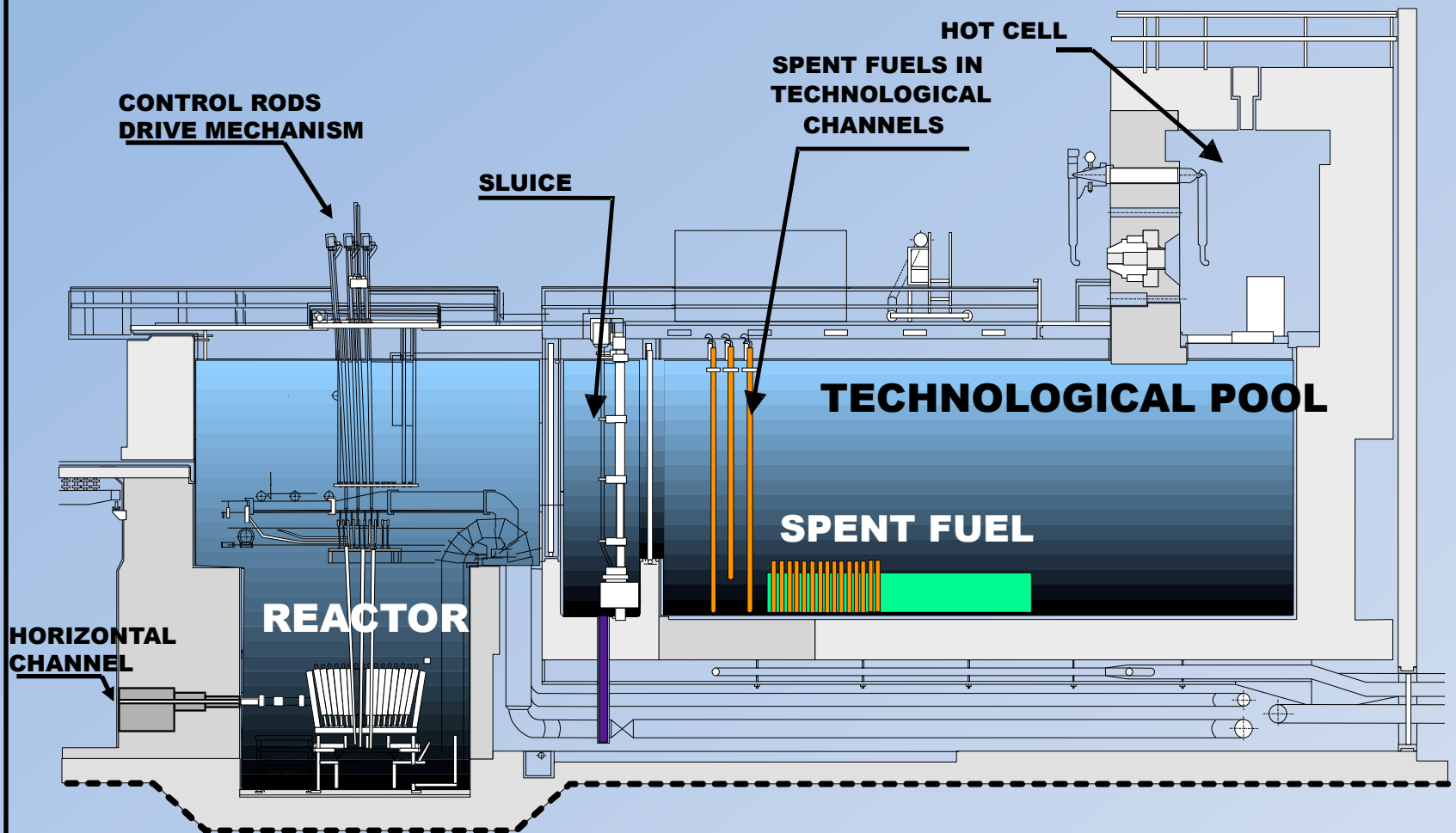

Fig.3. Cross section of the reactor pools

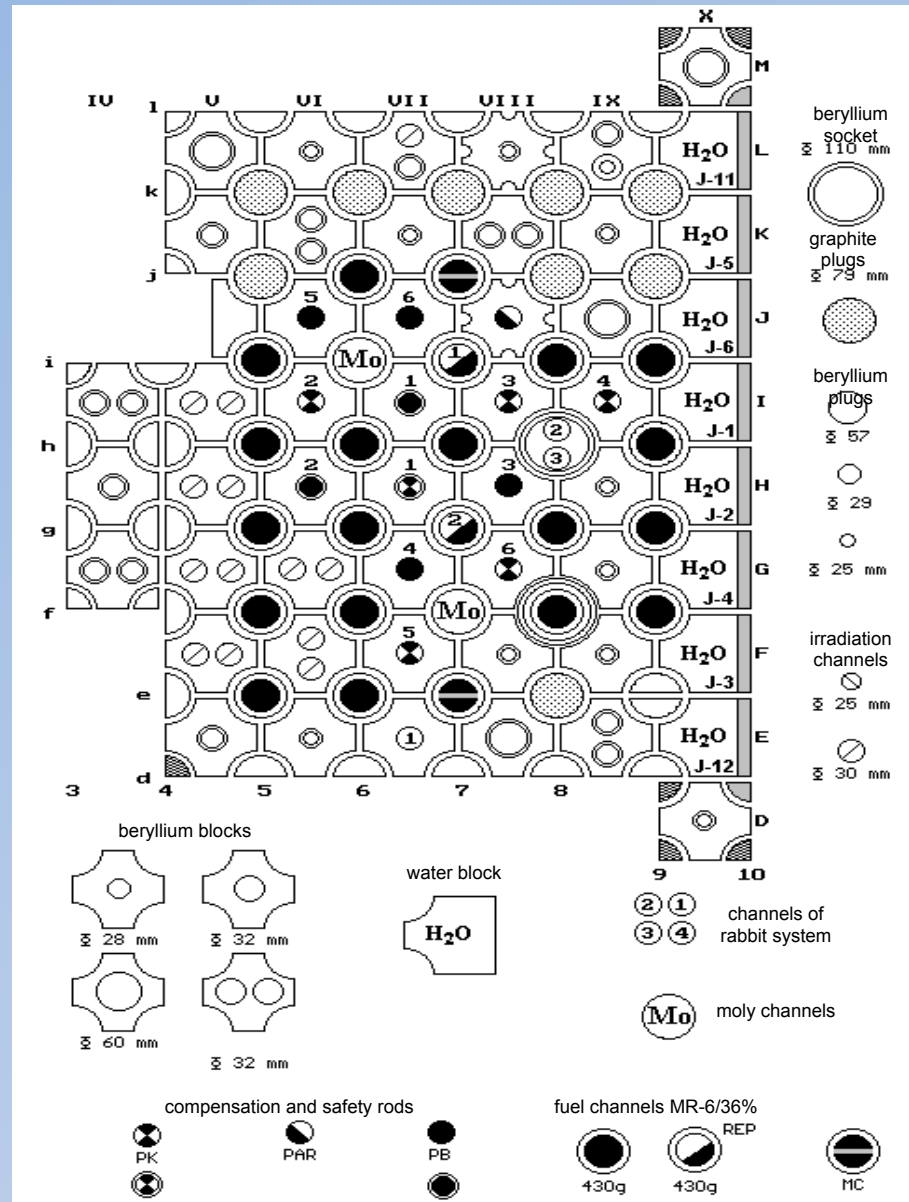
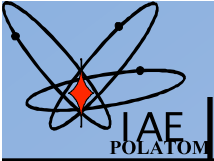

Fig.4. Configuration of reactor core



The main areas of reactor application are:

- production of radioisotopes,
- testing of fuel and structural materials for nuclear power engineering
- neutron radiography,
- neutron activation analysis
- neutron transmutation doping
- research in neutron and condensed matter physics
- training

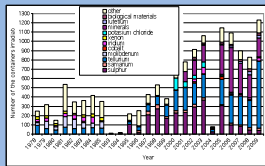
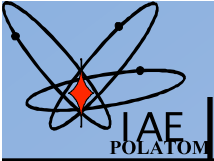

Fig.5. Distribution of target materials irradiated



3. Uranium plates irradiation for molybdenum production in MARIA reactor

Specific items:

- uranium plates are irradiated in typical fuel channel
- loading of irradiated plates into MARIANNE container is done in air

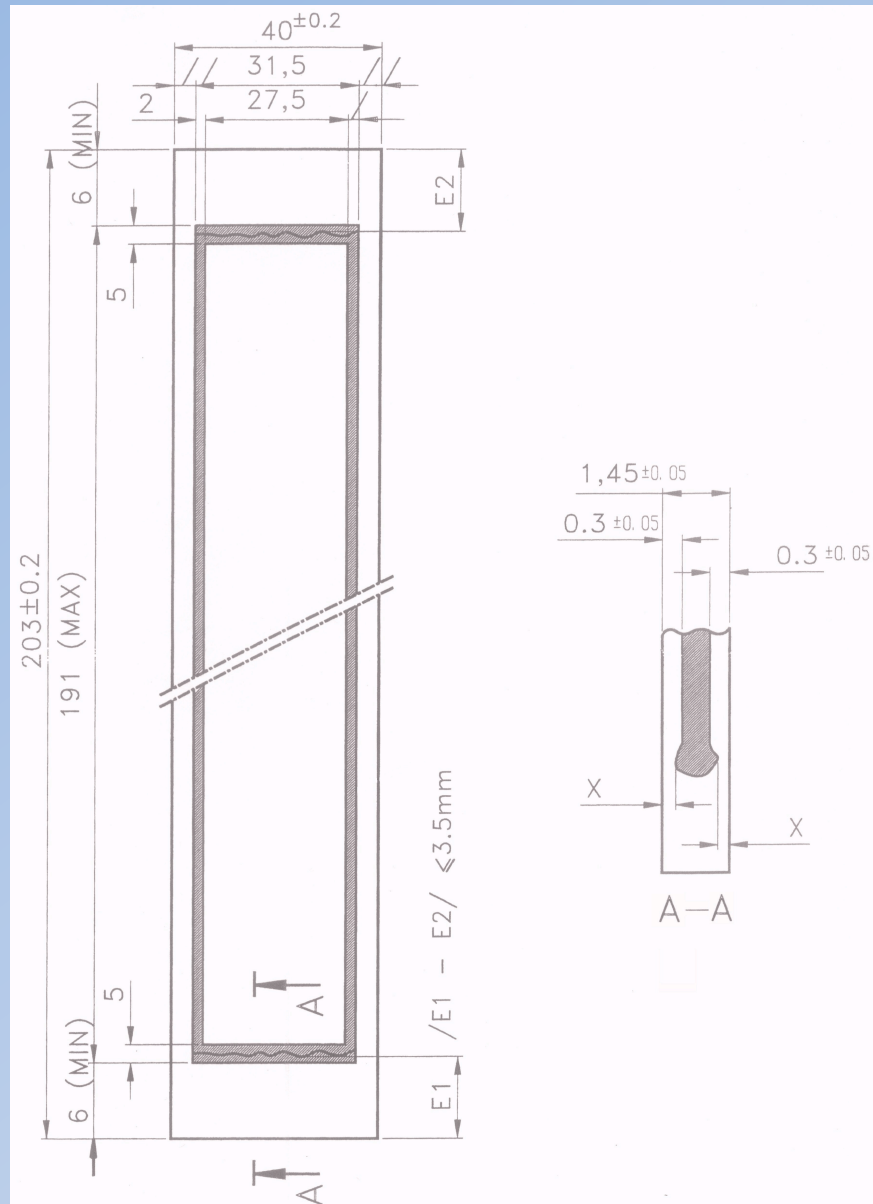

Fig.6. Uranium plate containing HEU (93% U²³⁵)

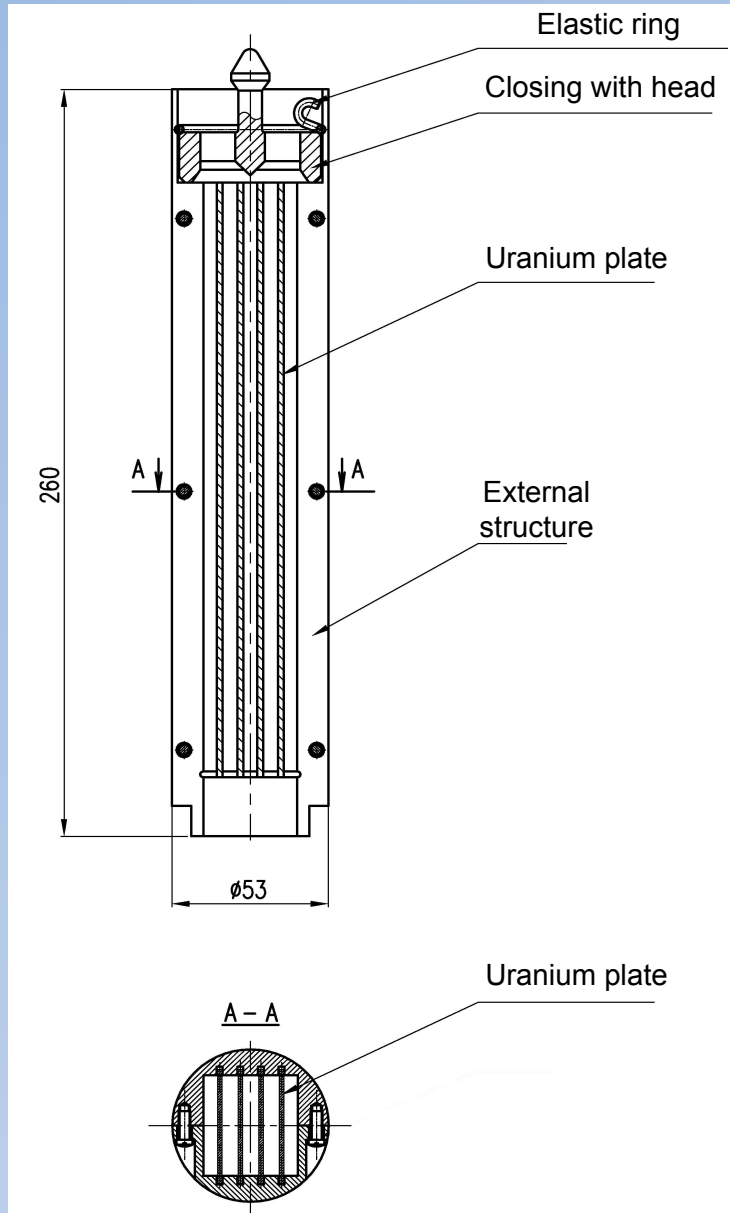

Fig.7. Container with 4 uranium plates

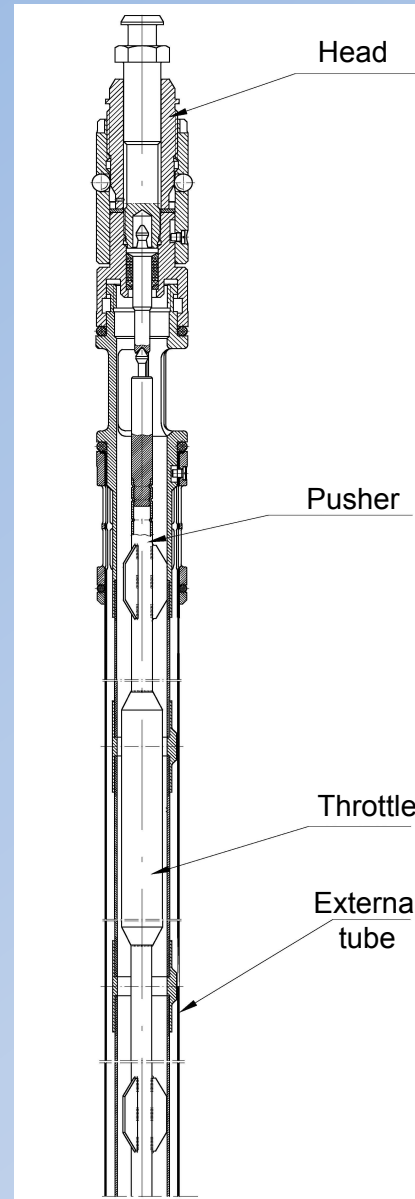

Fig.8. Upper part of irradiation channel

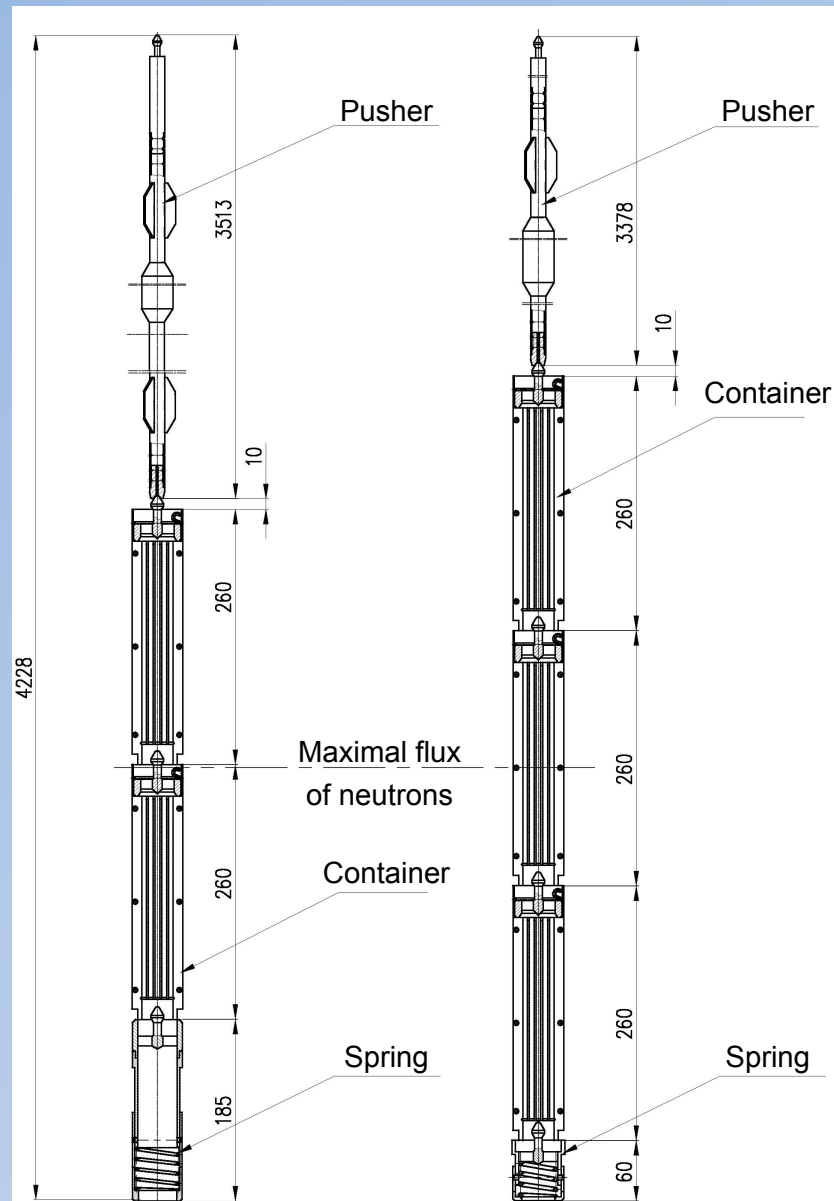
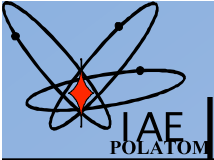
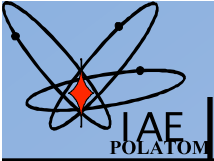

Fig.9. Set with 2 and 3 containers



Parameters of irradiation:

- power generated in molybdenum channel (for 8 plates):
170-210 kW
- activity reached : 7000 Ci – 8000 Ci
- time of irradiation : 115 – 144 hours
- flow rate of cooling water : 25 m³/h
- temperature difference : 7 – 8 °C
- cooling time of irradiated plates before evacuation
them to the hot cell : 12 – 15 hours



4. Transport of irradiated plates to the hot cell

Limit for transport (evacuation of plates from water) is:

Heat to be generated in the set of 8 plates $< 548 \text{ W}$

This limit is verified on the base of heat generated measurement using the special calorimeter.

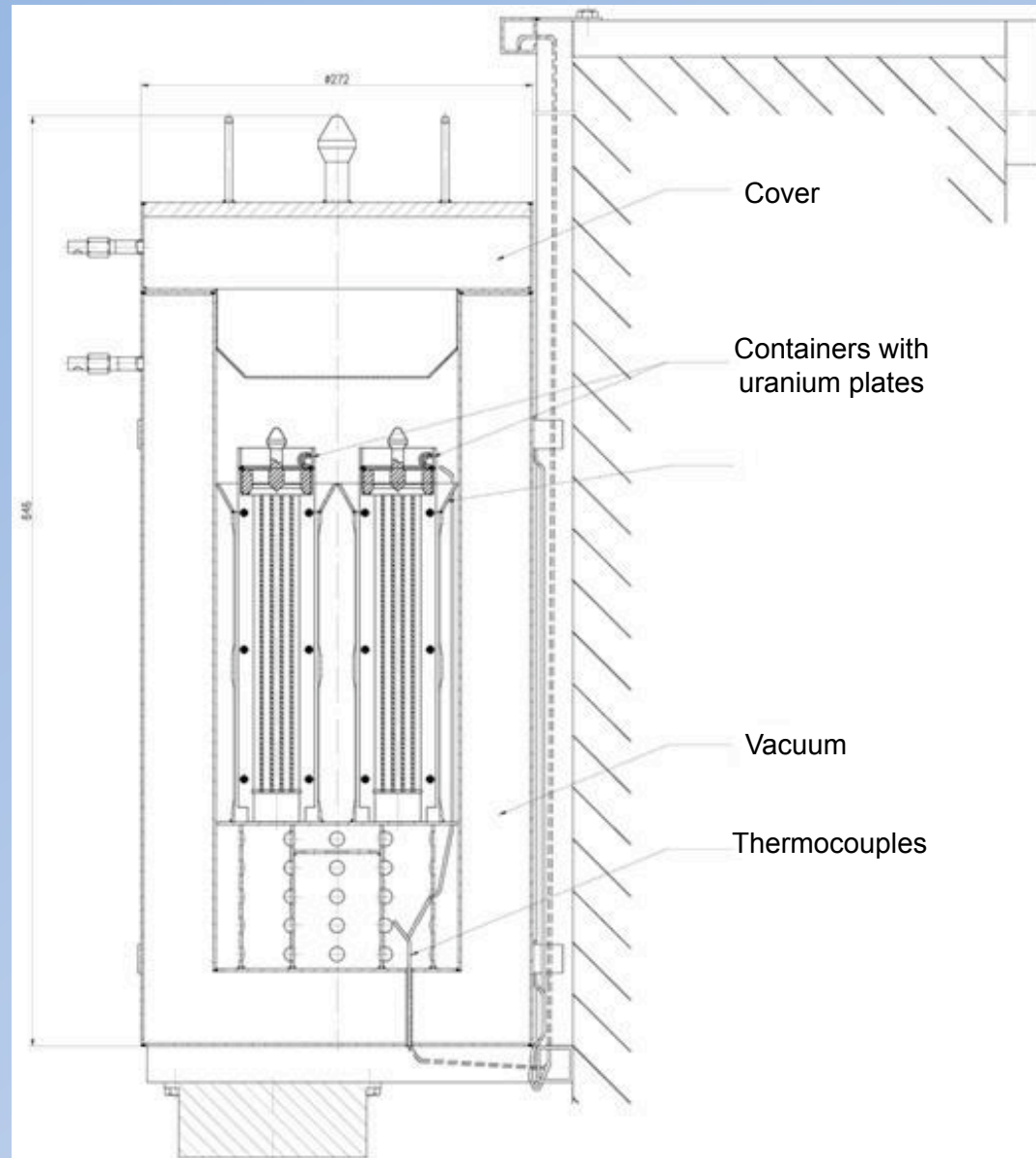

Fig.10. Calorimeter for shut-down heat measurement

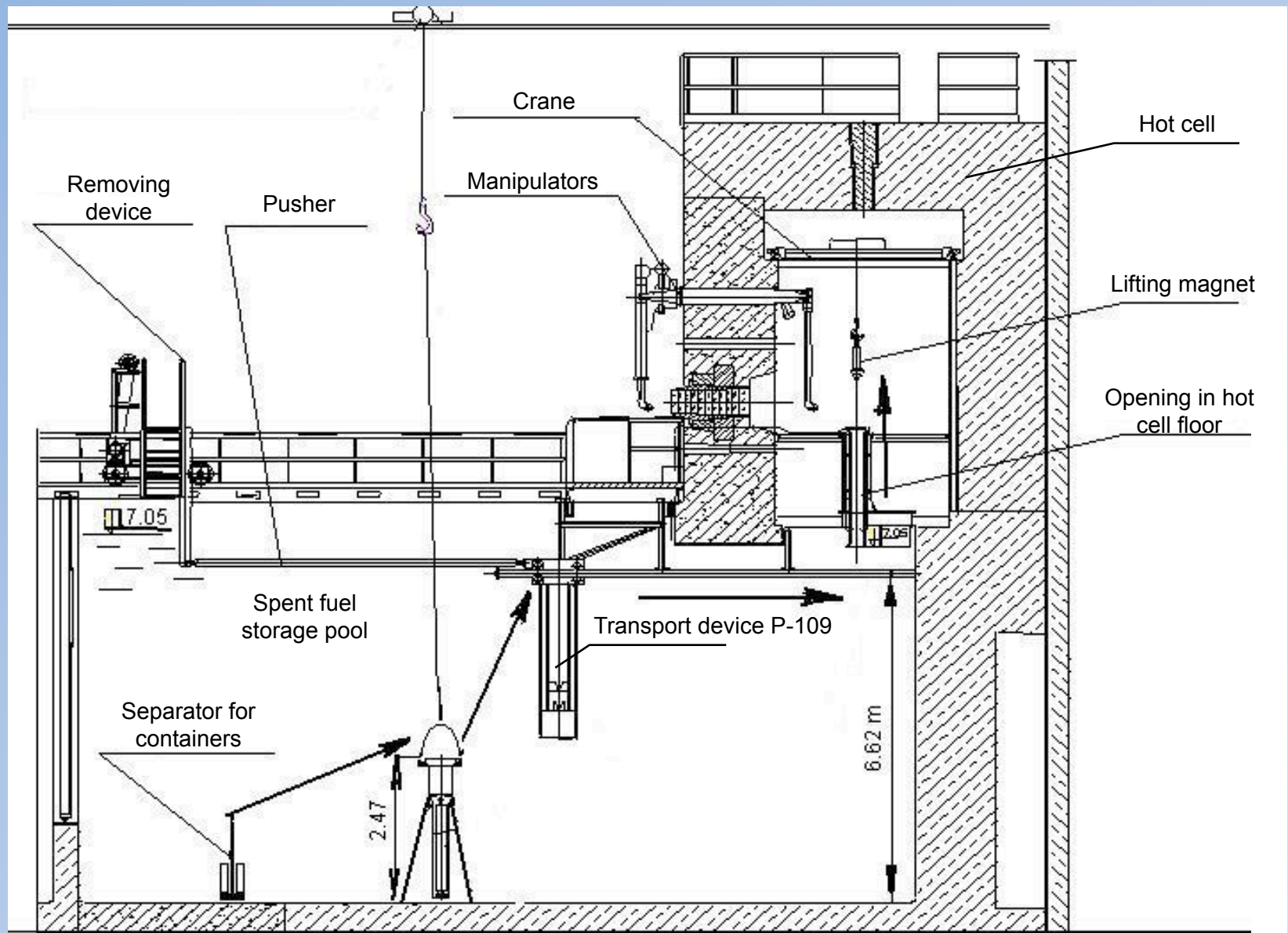

Fig.11. Scheme of irradiated plates transportation to the hot cell

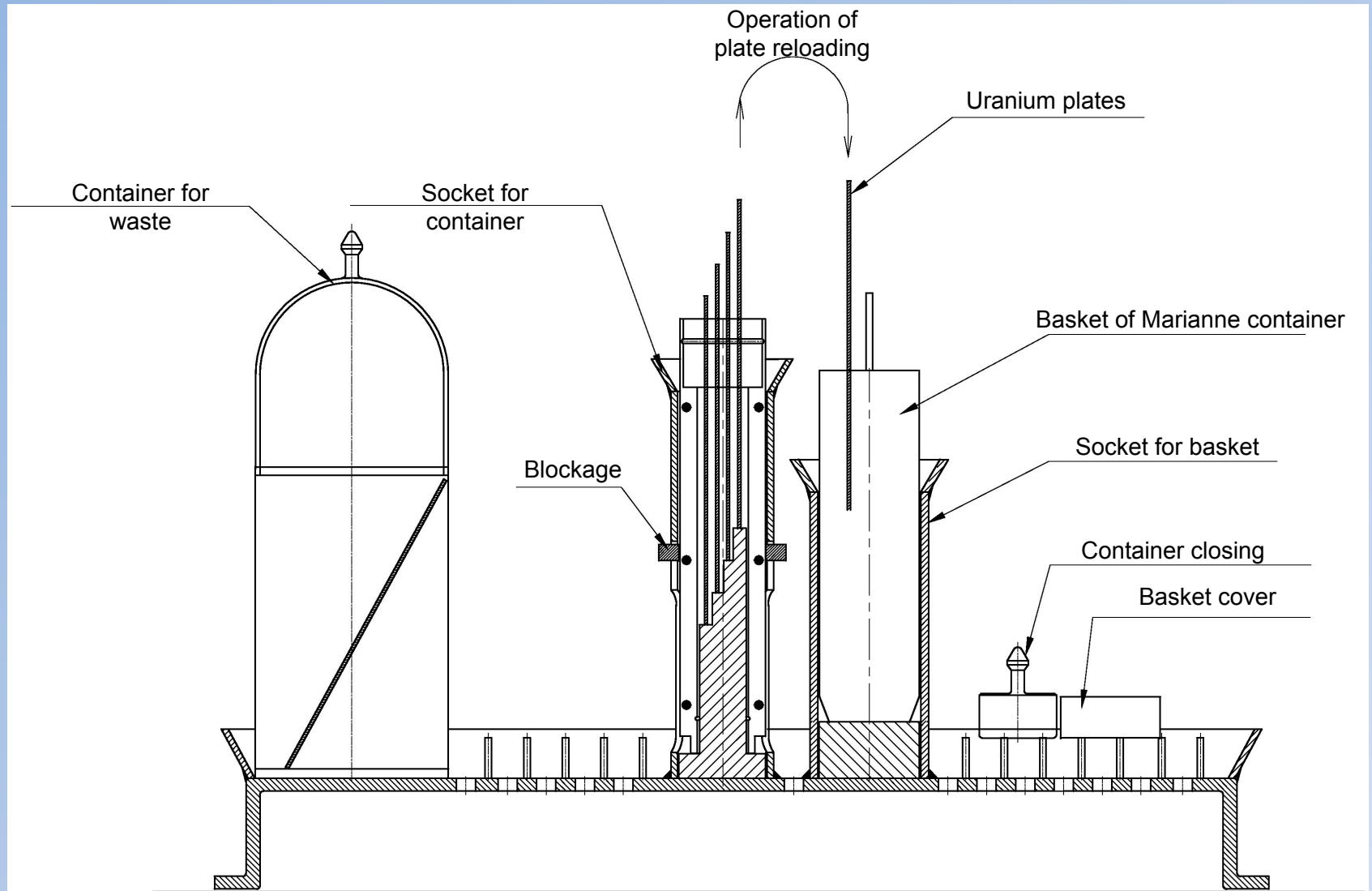

Fig.12. Scheme of irradiated plates reloading inside the hot cell

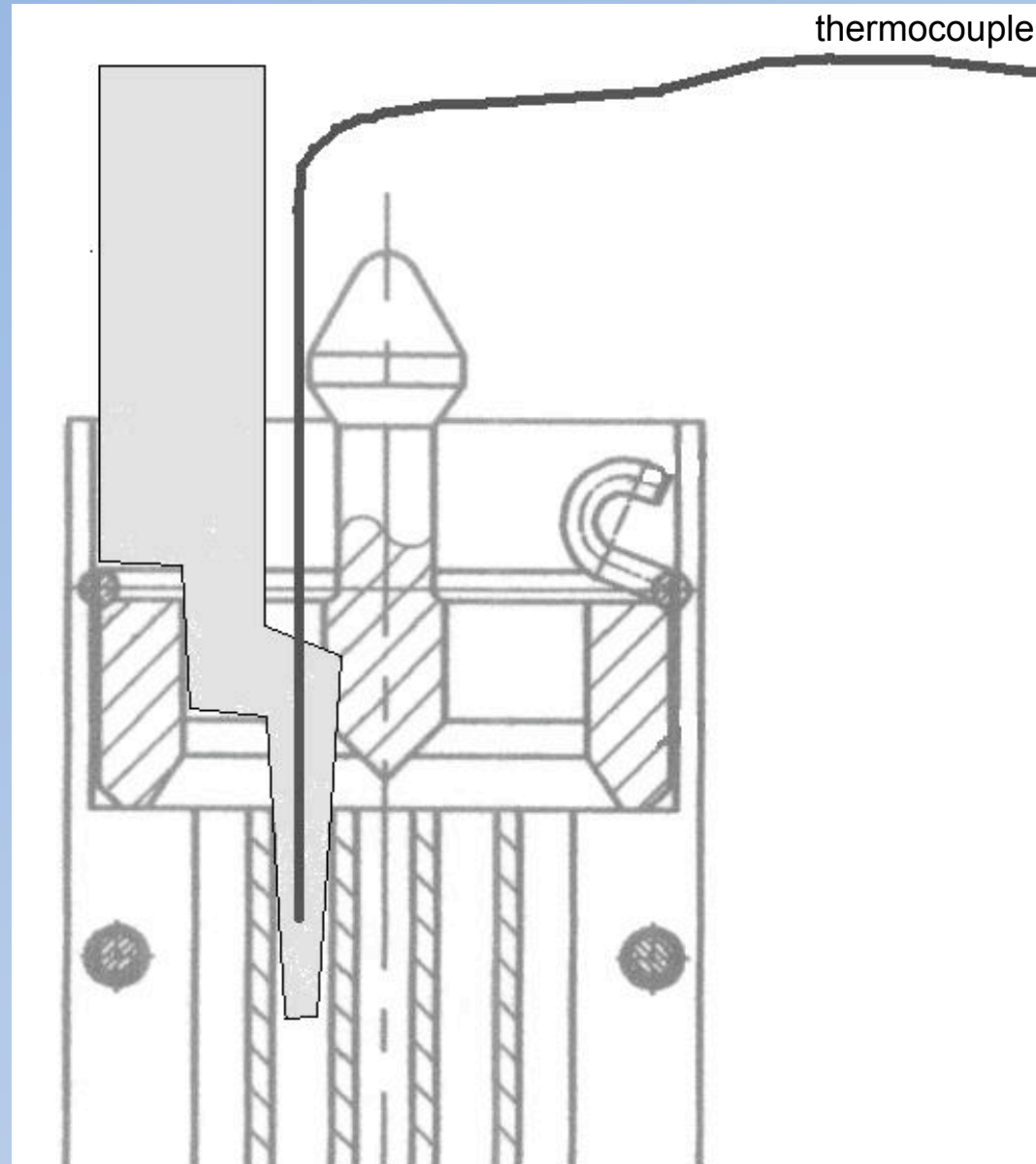
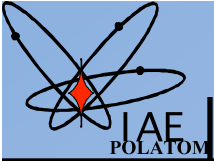

Fig.13. Scheme of plates temperature measurement



5. Loading of irradiated plates into Marianne container

- loading is done in the air through the hot cell
- loading is done in vertical orientation of container

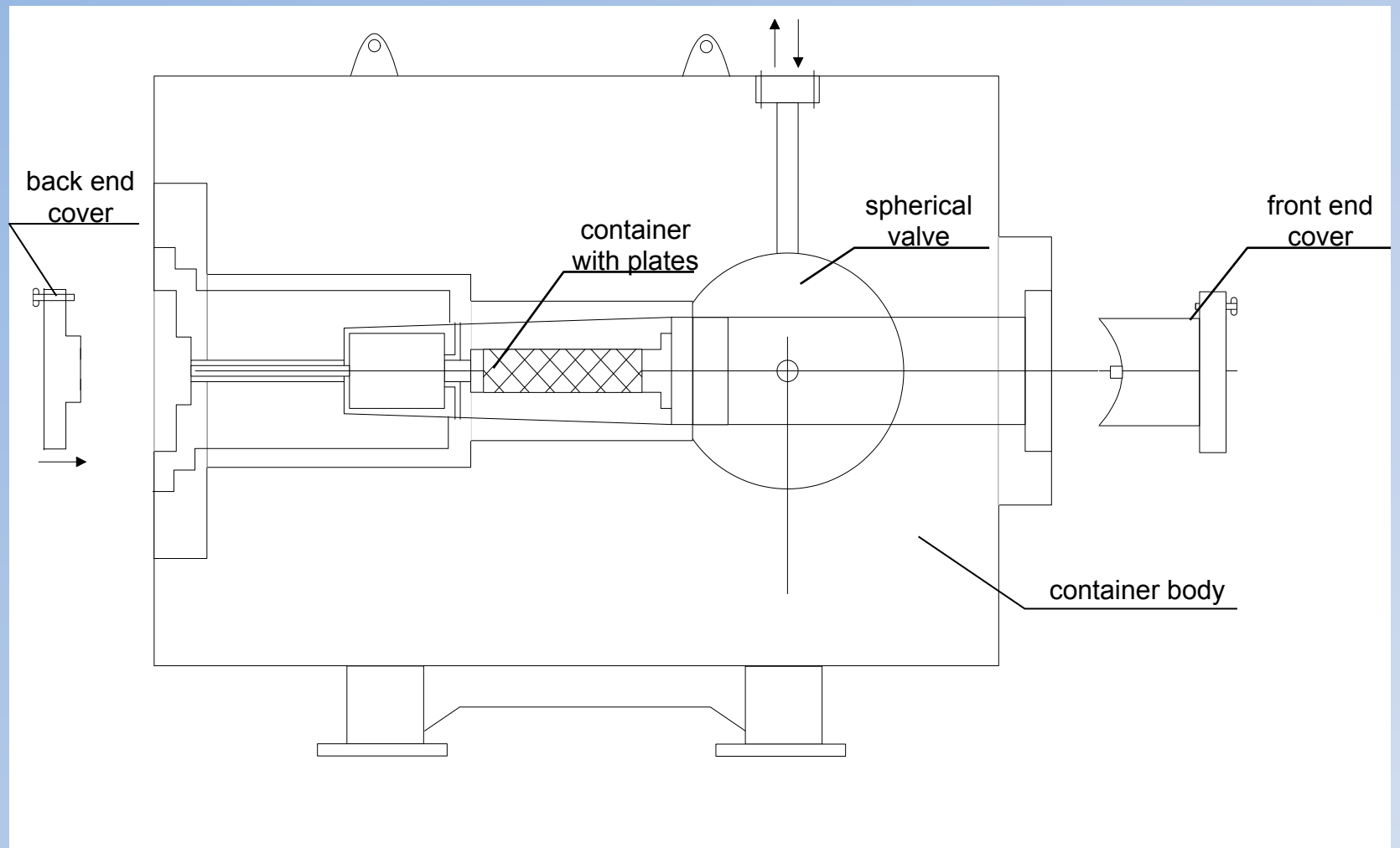
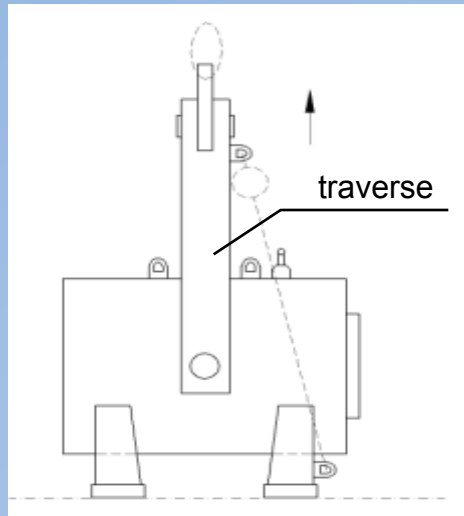
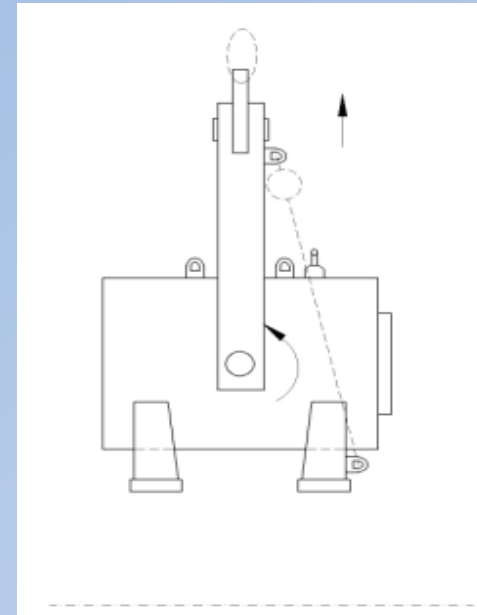

Fig.14. Container MARIANNE for irradiated plates transportation



a) Installation of traverse



b) Lifting of container and its turning

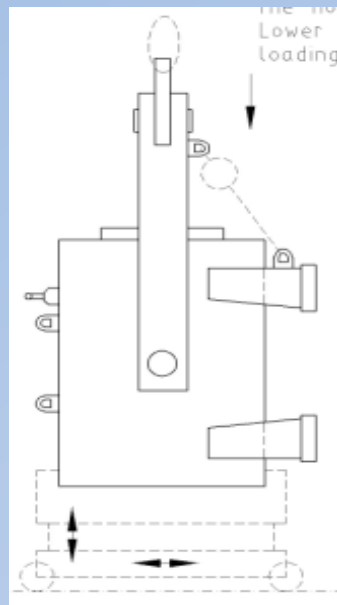

c) Positioning of container on the truck

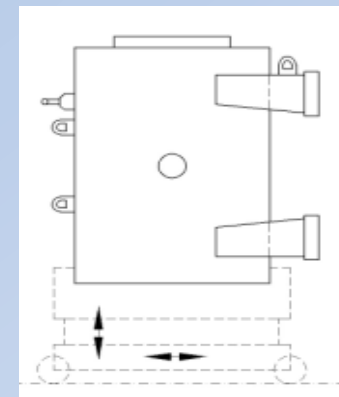

d) Transport of container under the positioning hot cell

Fig.15. Scheme of Marianne container positioning on the truck

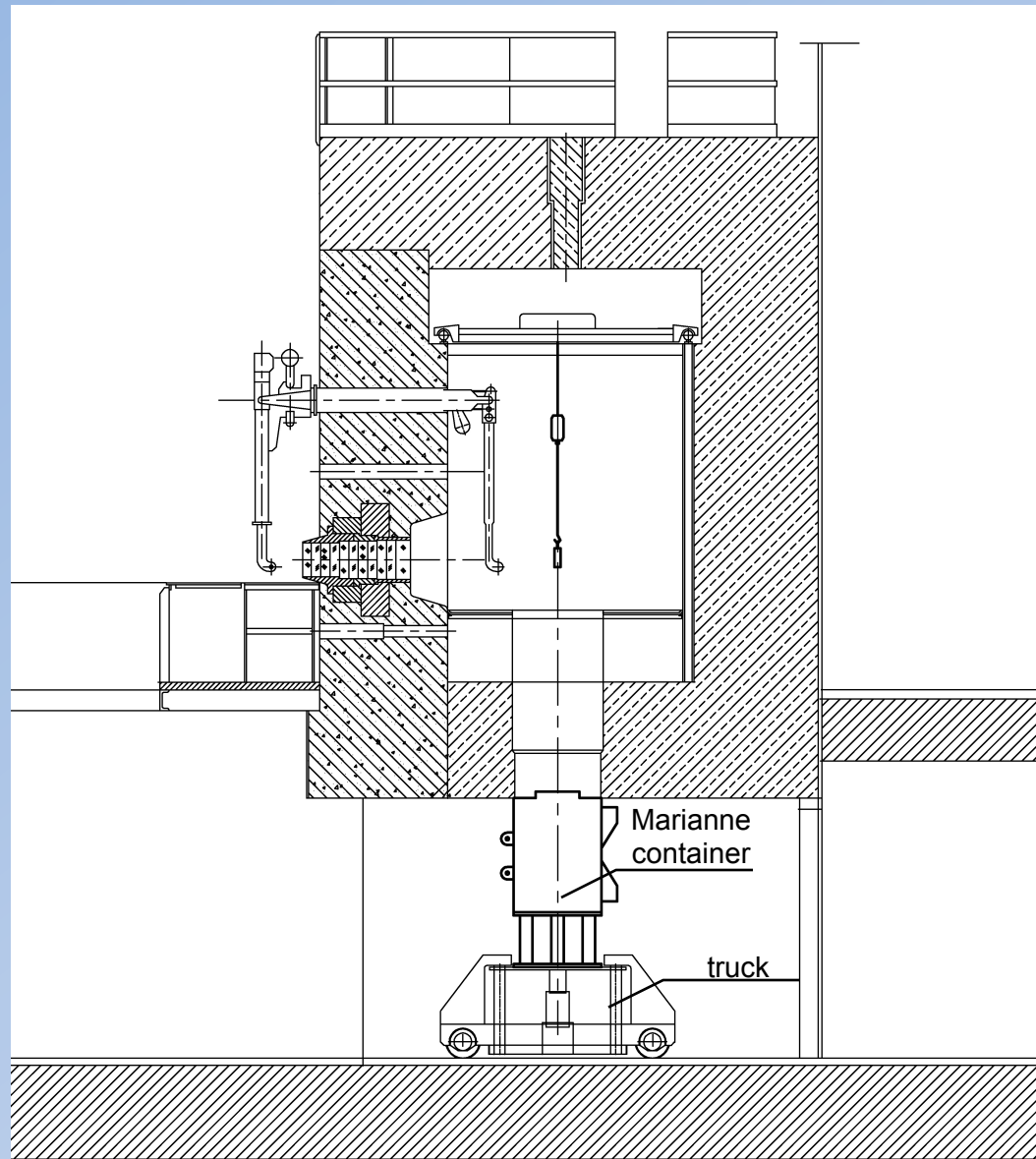
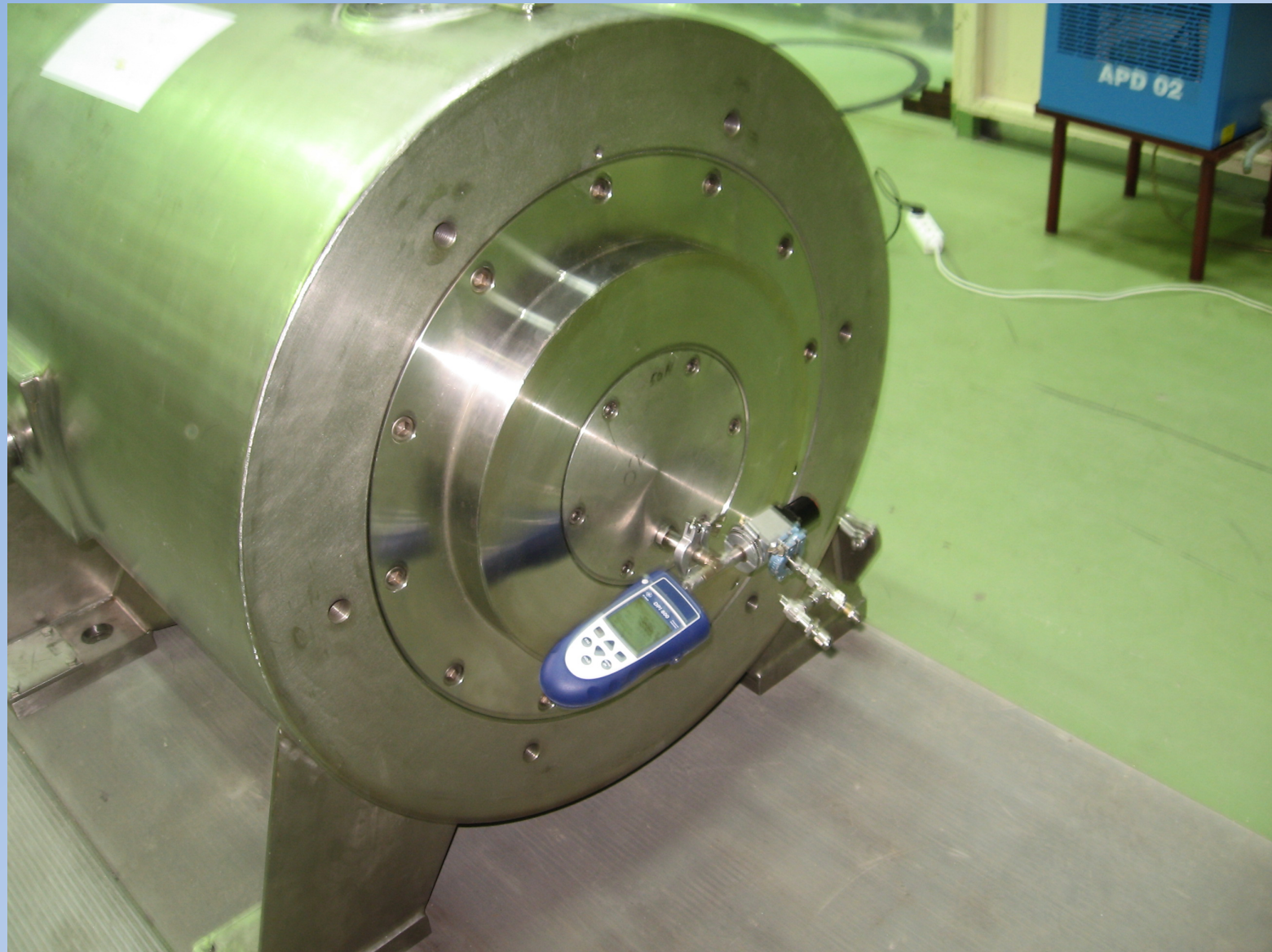

Fig.16. View of Marianne container on the truck under the hot cell







6. Conclusion

Implementation of molybdenum production in research reactor MARIA was performed in very short time. Total implementation time: project elaboration, manufacture of necessary equipments, tests and regulatory body approval was 8 months.

Until now total produced activity of Mo 99 is $2.4 \cdot 10^5$ Ci (EOI)